

► Mould Date Indicator (PPDI - F)

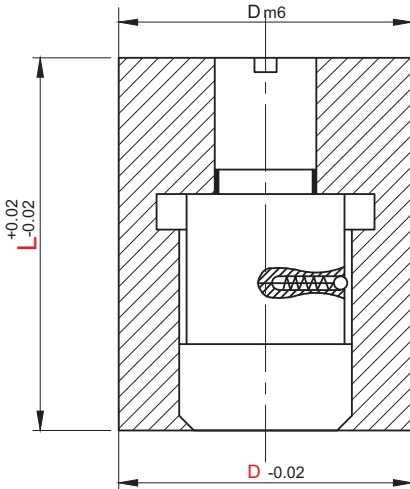

Material:- Tool Steel



Type								
Only Month	Only Year	Month & Year	Only Days	Only Quarter	Only Week	Only Shift Numeric	Only Shift Alphabets	Only Arrow

Code	ØD m6		L					
			6	8	10	12	14	16
PPDI-F	3	(+0.012) (+0.004)	*	*	*			
	4		*	✓	✓			
	6		*	✓	✓			
	8	(+0.015) (+0.006)		*	✓	*		
	10			*	✓	*		
	12	(+0.018) (+0.007)				✓	*	
	16						✓	
	20	(+0.021) (+0.008)					*	*

Order Type:- Code x D x L (Type)
Example:- PPDI-F x 4 x 10 (Only Year)

► Mould Date Indicator (PPDI-C)

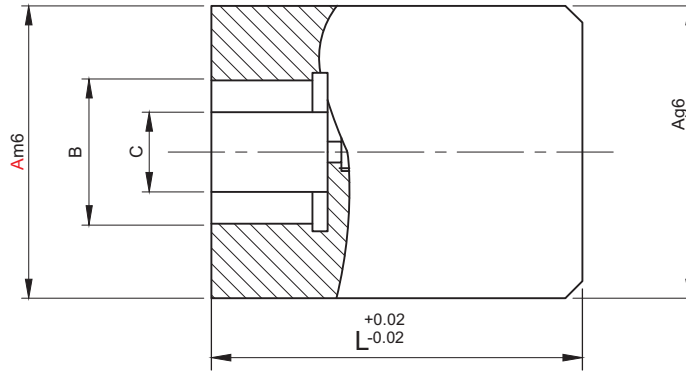

Material:- Tool Steel

Type	ØAm6		ØAg6		ØB	ØC	L
PPDI-C	8	(+0.015) (+0.006)	8	(-0.005) (-0.014)	5.8	3.6	10
	10		10		7	4	12
	12	(+0.018) (+0.007)	12	(-0.006) (-0.017)	8.5	5	14
	16		16		11.5	7	14
	20	(+0.021) (+0.008)	20	(-0.007) (-0.020)	14	8	16

Order Type :- Type x A
Example :- PPDI-C x 8

► Muold Short Counter (PPMC)

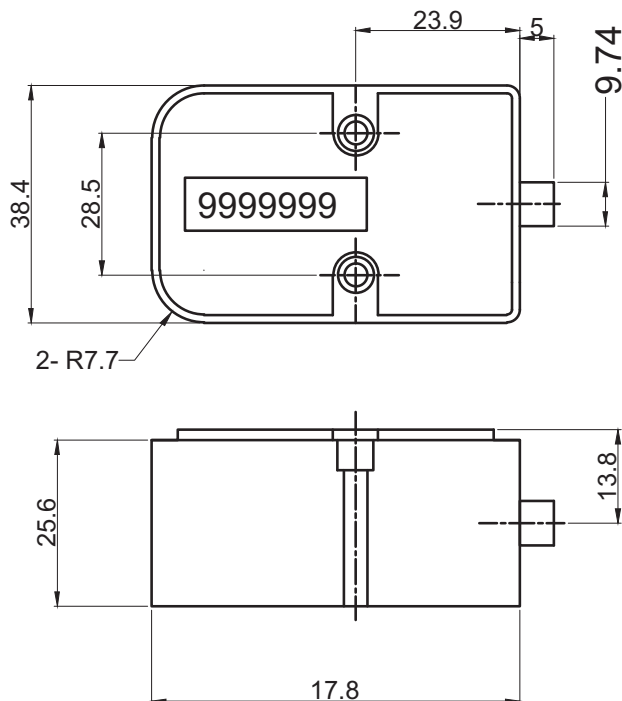

Code	Screw Size
PPMC-01	M4x0.7x25

Order Type:- Code
Example:- PPMC-01